

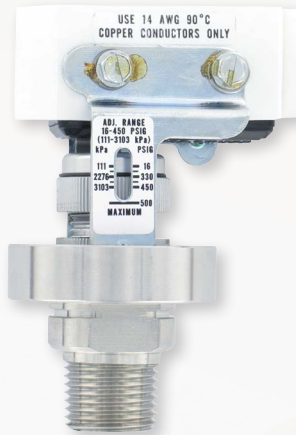

SERIES A1F | MERCOID® LOW COST OEM PRESSURE SWITCH



A1F



A1F with -PC weatherproof housing

FEATURES/BENEFITS

- 15 A contact allows direct control reducing costs and reliability by having to introduce additional contacts and relays
- Case style allows use for panel mounting application with optional weather-proof enclosure for use in outdoor environments
- Field adjustable reduces installation time bring application on-line faster
- Wetted material provides support for wider range of process media

APPLICATIONS

- OEM
- Compressors
- Motor control
- Process equipment
- Pump control

DESCRIPTION

Low cost and precision made, the **Series A1F Low Cost OEM Pressure Switch** is ideal for OEM industrial applications. Wetted materials of 316 SS and fluorocarbon ensure great chemical compatibility with a wide range of process media. The open case style is perfect for panel mounting applications like pump skids. Weatherproof enclosure is available in polycarbonate offering a low cost weatherproof switch. Superior 15 A contact allows direct control of motors or pumps without the use of external relays, a true cost savings.

SPECIFICATIONS

Service	Compatible liquids and gases.
Wetted Materials	Pressure chamber: 316 SS; Diaphragm: Fluorocarbon.
Temperature Limit	-40 to 175°F (-40 to 80°C).
Pressure Limits	500 psig (34 bar).
Enclosure Rating	No rating for open construction. Optional -PC enclosure meets NEMA 4X standards.
Switch Type	SPDT snap switch.
Electrical Rating	15 A @ 120/240/480 VAC, 1/8 HP @ 125 VAC, 1/4 HP @ 250 VAC.
Electrical Connection	Screw terminals.
Process Connection	1/4" female NPT and 1/2" male NPT.
Mounting Orientation	Within 20° of vertical.
Set Point Adjustment	Knurled screw cap with indicating scale.
Deadband	Fixed, see products on Order page for minimum and maximum deadband.
Weight	10.5 oz (297 g).
Agency Approvals	CE, cUL, UL.

DIMENSIONS

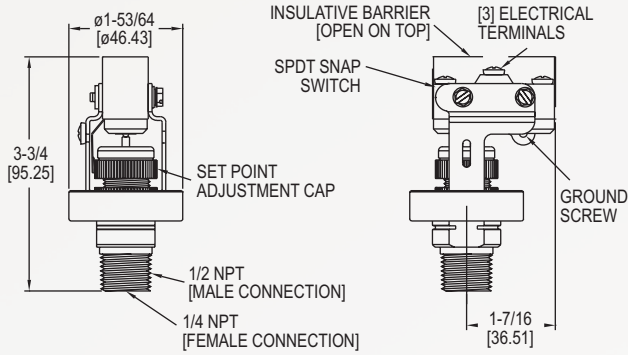

A1F

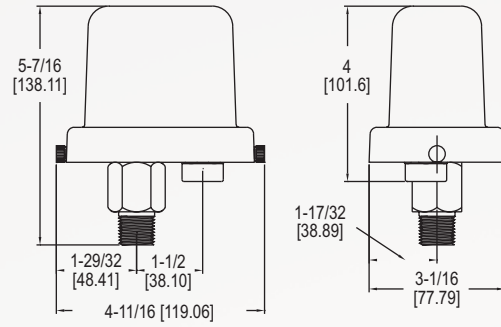

A1F with -PC weatherproof housing

HOW TO ORDER

Use the **bold** characters from the chart below to construct a product code.

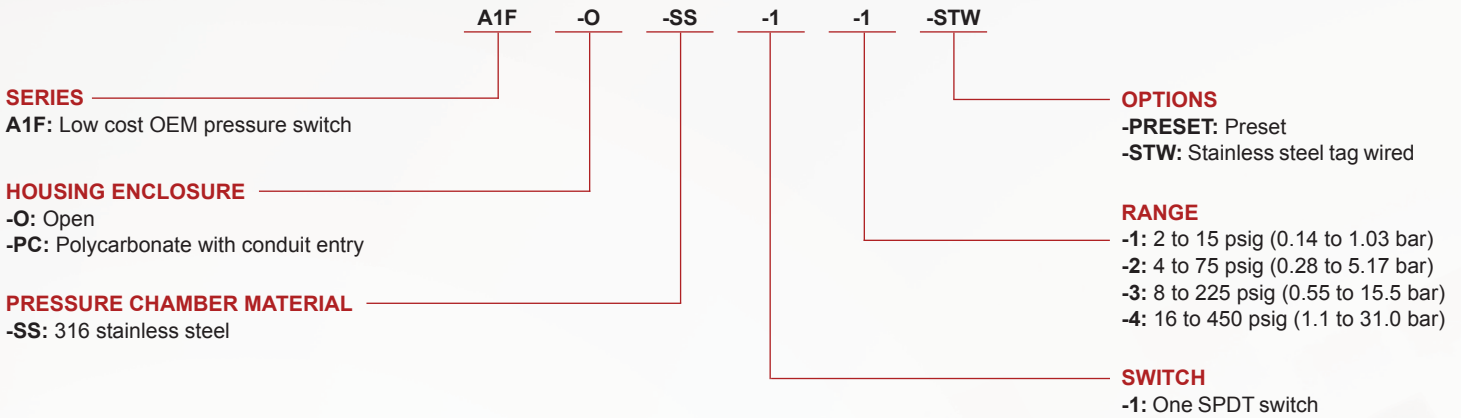

ORDER ONLINE TODAY!
dwyer-instruments.com/Product/SeriesA1F



DWYER INSTRUMENTS, INC.